



# **C&D TRUE FRONT ACCESS®**

**TEL12-160FW**  
**TEL12-160F**  
**TEL12-180F**



## **THE MOMENT OF TRUTH HAS ARRIVED**

- TRUE Performance** - 100% out of box capacity ratings at installation
- TRUE Front Access Terminals** - ensuring reliability & connection versatility
- TRUE High Energy Density** - highest true energy density solution in the market
- TRUE Long life design** - Telcordia SR-4228 industry leading 13 year service life
- TRUE Seismic System** - highest capacity energy storage system seismic NEBS tested
- TRUE Flexibility** - multiple models to fit each customers unique power system demands

## **PRODUCT LINE EXTENSION TO C&D TEL VALVE REGULATED LEAD ACID (VRLA) BATTERY SERIES**

### **FEATURES & BENEFITS**

#### **APPLICATIONS**

- Wireline
- Wireless
- Customer Premise / PBX
- Broadband
- Microwave Repeater
- Fiber Optic Regen Sites

#### **INDOOR/OUTDOOR INSTALLATIONS**

- Cabinet Systems
- Rack Systems

- Long life alloy and design Telecordia certified exceeding 13 years service life.
- Tested and qualified by Telecordia to meet SR-4228 requirements.
- True Front Access threaded copper alloy inserts for reduced maintenance and increased safety.
- Terminal versatility - ease of diagnostic readings with Ohmic Ring™
- Reduced headspace driving higher energy density, in cabinet or rack applications
- Removable handles for ease of installation
- Innovative front terminal design maximizing energy density with direct connect extrusion fusion weld technology.
- Thermally welded case-to-cover bond to ensure a leak-proof seal.
- Flame-retardant polypropylene case and cover compliant with UL94 V-O with an Oxygen Limiting Index of greater than 28.
- Absorbent Glass Mat (AGM) technology for efficient gas recombination 99% plus.
- Flame-arresting, one-way pressure-relief vent for safety and long life.
- Complies with UL1778, 924, 1989 and 94 V-0. BS6290PT4, IEC-896-2.
- UL-recognized component.
- Multicell design for ease of installation and maintenance.
- Not restricted for air transport - Complies with IATA/ICAO Special Provision A67.
- Not restricted for surface transport - classified as non-hazardous material as related to DOT-CFR Title 49 parts 17 1-189.
- Not restricted for water transport - classified as non-hazardous material per Amendment 27.

## SPECIFICATIONS

Ampere Hour Capacity to 1.75 Volts per Cell @ 77°F (25°C)

Discharge in Hrs.

Model	1	2	3	4	5	6	7	8	9	10	12	16	20	24	36	48	72	100
TEL12-160FW	111.1	127.4	137.2	143.8	149.0	153.1	156.7	159.7	162.1	164.1	167.6	172.9	176.6	179.6	185.4	189.0	193.2	195.8
TEL12-160F	107.1	124.4	134.6	141.5	146.7	150.8	154.3	157.3	159.5	161.5	164.7	169.4	172.6	174.9	179.2	181.4	183.4	183.8
TEL12-180F	123.1	143.5	155.2	163.2	169.2	174.0	177.9	181.2	184.0	186.4	190.4	196.3	200.3	203.3	208.9	211.9	214.6	215.5

<b>Operating Temperature Range with temperature compensation</b>	Discharge: -40°F (-40°C) to +160°F (71°C) Charge: -10°F (-23°C) to +140°F (60°C)												
<b>Nominal Operating Temperature Range</b>	+74°F (23°C) to +80°F (27°C)												
<b>Recommended Maximum Charging Current Limit</b>	C/5 amperes @ 20 Hr rate												
<b>Float Charging Voltage</b>	13.5 to 13.8 VDC average per 12V unit												
<b>Maximum AC Ripple (Charger)</b>	0.5% RMS or 1.5% P-P of float charge voltage recommended for best results. Max voltage allowed = 1.4% RMS (4% P-P) Max current allowed = C/20												
<b>Self Discharge</b>	Battery can be stored up to 6 months at 77°F (25°C) before a freshening charge is required. Batteries stored at temperatures greater than 77°F (25°C) will require recharge sooner than batteries stored at lower temperatures. See C&D brochure 41-7272, Self-Discharge and Inventory Control for details.												
<b>Equalize charge and cycle service voltage</b>	14.40 to 14.80 VDC average per 12V unit @ 77°F (25°C)												
<b>Terminal: Inserted - Inter-unit connector provided</b>	Threaded copper alloy insert terminal to accept 1/4-20 UNC bolt												
<b>Terminal Hardware Initial Torque:</b>	110 in.-lbs. (12.4 N-m)												
<b>Telcordia Part Numbers</b>	<table border="0"> <thead> <tr> <th>Battery Part Number</th> <th>CLEI Code</th> <th>CPR</th> </tr> </thead> <tbody> <tr> <td>TEL12-160FW</td> <td>PBMBC10FRA</td> <td>212312</td> </tr> <tr> <td>TEL12-160F</td> <td>PMBBB10FRA</td> <td>212304</td> </tr> <tr> <td>TEL12-180F</td> <td>PBMBD10FRA</td> <td>212314</td> </tr> </tbody> </table>	Battery Part Number	CLEI Code	CPR	TEL12-160FW	PBMBC10FRA	212312	TEL12-160F	PMBBB10FRA	212304	TEL12-180F	PBMBD10FRA	212314
Battery Part Number	CLEI Code	CPR											
TEL12-160FW	PBMBC10FRA	212312											
TEL12-160F	PMBBB10FRA	212304											
TEL12-180F	PBMBD10FRA	212314											

Battery	Voltage Per Unit	Ampere Hour Capacity 8 Hour Rate @ 77°F (25°C) to 1.75 v/c	Ampere Hour Capacity 10 Hour Rate @ 68°F (20°C) to 1.80 v/c	Maximum Discharge Current	Short Circuit Current	Ohms Impedance 60 Hz (Ω)	Battery Weight
TEL12-160FW	12 V Monobloc	160 Ah	153 Ah	800 Amperes	5600 Amperes	0.0027 Ohms	121 lbs / 55 kg
TEL12-160F	12 V Monobloc	157 Ah	151 Ah	800 Amperes	4700 Amperes	0.0031 Ohms	115 lbs / 53 kg
TEL12-180F	12 V Monobloc	181 Ah	174 Ah	800 Amperes	4500 Amperes	0.0037 Ohms	131 lbs / 60 kg

# DIMENSIONS

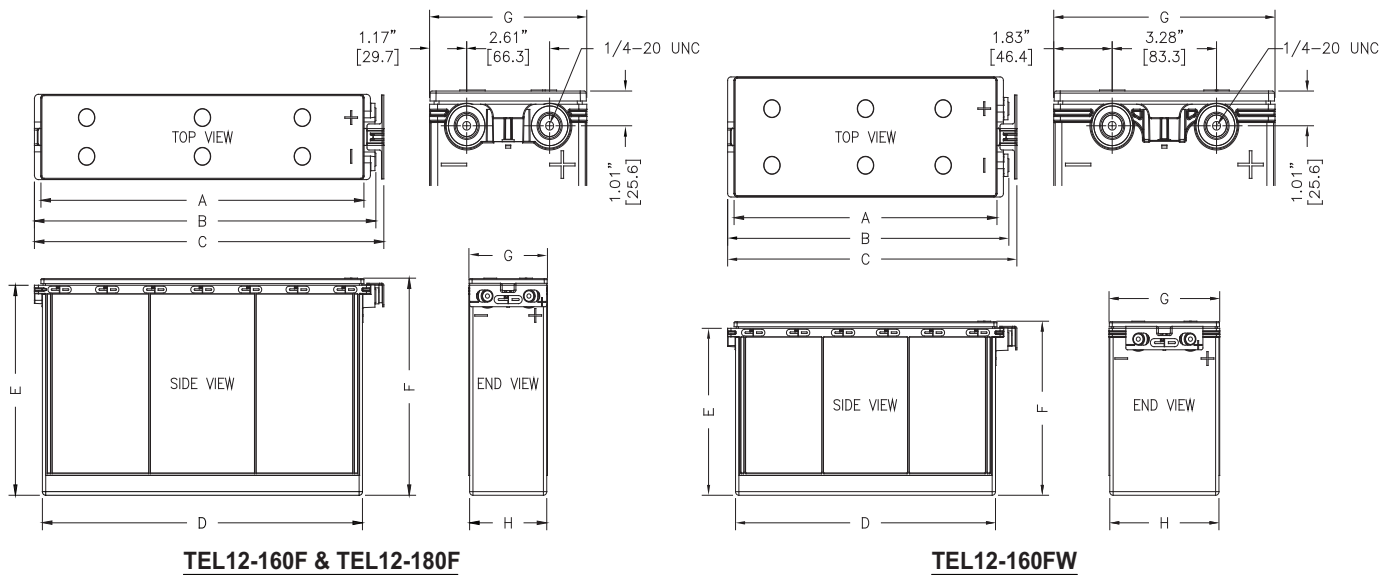

MODEL	A		B		C		D		E		F		G		H	
	in	mm	in	mm	in	mm	in	mm	in	mm	in	mm	in	mm	in	mm
TEL12-160FW	16.56	420.57	17.72	449.99	18.22	462.79	16.37	415.90	9.69	246.05	10.10	256.54	6.94	176.33	6.88	174.70
TEL12-160F	20.35	516.86	21.51	546.25	22.01	559.05	20.16	512.17	10.73	272.47	11.14	282.96	4.95	125.73	4.86	123.39
TEL12-180F	20.35	516.86	21.51	546.25	22.01	559.05	20.16	512.17	12.19	309.55	12.60	320.04	4.95	125.73	4.86	123.39

\* All dimensions in inches and (millimeters). All dimensions are for reference only. Contact a C&D Representative for complete dimensions information.  
 \* Note: Batteries to be mounted with 0.5 IN (1.25CM) spacing minimum and free air ventilation.

## CONSTANT CURRENT RATINGS - AMPERES @ 77°F (25°C)

### TEL12-160FW

End point volts/cell	Operating Time (hr)																	
	1	2	3	4	5	6	7	8	9	10	12	16	20	24	36	48	72	100
1.75	111.1	63.7	45.7	36.0	29.8	25.5	22.4	20.0	18.0	16.4	14.0	10.8	8.8	7.5	5.2	3.9	2.7	2.0
1.80	107.1	62.0	44.7	35.3	29.3	25.1	22.0	19.7	17.7	16.2	13.8	10.6	8.7	7.4	5.1	3.9	2.6	1.9
1.85	99.2	58.6	42.6	33.7	28.1	24.1	21.2	18.9	17.1	15.6	13.3	10.3	8.4	7.1	4.8	3.7	2.5	1.8
1.90	87.0	52.7	38.8	30.9	25.8	22.2	19.6	17.5	15.8	14.4	12.3	9.5	7.7	6.5	4.4	3.3	2.2	1.6

### TEL12-160F

End point volts/cell	Operating Time (hr)																	
	1	2	3	4	5	6	7	8	9	10	12	16	20	24	36	48	72	100
1.75	107.1	62.2	44.9	35.4	29.3	25.1	22.0	19.7	17.7	16.1	13.7	10.6	8.6	7.3	5.0	3.8	2.5	1.8
1.80	102.7	60.3	43.7	34.5	28.7	24.6	21.6	19.3	17.4	15.9	13.5	10.4	8.5	7.2	4.9	3.7	2.5	1.8
1.85	95.2	56.9	41.6	33.0	27.5	23.6	20.8	18.5	16.7	15.3	13.0	10.0	8.2	6.9	4.7	3.5	2.4	1.7
1.90	83.7	51.2	37.7	30.1	25.2	21.7	19.1	17.1	15.4	14.1	12.0	9.2	7.5	6.3	4.3	3.2	2.1	1.5

### TEL12-180F

End point volts/cell	Operating Time (hr)																	
	1	2	3	4	5	6	7	8	9	10	12	16	20	24	36	48	72	100
1.75	123.1	71.7	51.7	40.8	33.8	29.0	25.4	22.6	20.4	18.6	15.9	12.3	10.0	8.5	5.8	4.4	3.0	2.2
1.80	117.3	69.6	50.6	40.0	33.3	28.6	25.0	22.3	20.2	18.4	15.6	12.1	9.8	8.3	5.6	4.3	2.9	2.1
1.85	107.9	65.5	48.0	38.3	31.9	27.4	24.1	21.5	19.4	17.7	15.1	11.6	9.5	8.0	5.4	4.1	2.7	2.0
1.90	95.1	59.1	43.8	35.1	29.4	25.3	22.3	19.9	18.0	16.4	14.0	10.8	8.8	7.4	5.0	3.7	2.5	1.8

# FRONT ACCESS BATTERY RACK SYSTEMS

- TRUE High Energy Density with TEL12-180F
- Front Access for Ease of Installation and Maintenance
- Pre Wired from the Factory
- Integrated Grounding Hardware and Multiple Grounding points
- TRUE Seismic Systems Shaker Table Tested
- Tested to GR-63-CORE and GR-1089-CORE
- Cable Management System
- Thermal Management Features Ensuring Long Life

## Five Tier Seismic Zone 2



### NEBS Level 3 Zone 2

Standard Breaker Panel  
Optional Bus Panel  
+24VDC 1800 Ah  
-48VDC 900 Ah

Height = 82.13 inches (2086 mm)  
Width = 23.5 inches (597 mm)  
Depth = 22.52 inches (572 mm)  
Weight = 300 lbs (136 kgs)  
(without batteries)

NEBS Zone 2 5-Tier Racks	
System Part Number	Description
110-7050-01	(+) 24VDC Top Common Bus
110-7050-02	(+) 24VDC 10x 100A Ckt Bkrs
110-7050-05	(-) 48VDC Top Common Bus
110-7050-06	(-) 48VDC 5x 100A Ckt Bkrs

## Five Tier Seismic Zone 4



### NEBS Level 3 Zone 4

Standard Breaker Panel  
Optional Bus Panel  
+24VDC 1800 Ah  
-48VDC 900 Ah

Height = 80.69 inches (2050 mm)  
Width = 24.88 inches (632 mm)  
Depth = 23.63 inches (600 mm)  
Weight = 375 lbs (170 kgs)  
(without batteries)

NEBS Zone 4 5-Tier Racks	
System Part Number	Description
110-7051-01	(+) 24VDC Top Common Bus
110-7051-02	(+) 24VDC 10x 100A Ckt Bkrs
110-7051-05	(-) 48VDC Top Common Bus
110-7051-06	(-) 48VDC 5x 100A Ckt Bkrs

## Six Tier Seismic Zone 4



### NEBS Level 3 Zone 4

Standard Bus Panel  
Optional Side Breakers  
+24VDC 2160 Ah  
-48VDC 1080 Ah

Height = 84 inches (2134 mm)  
Width = 24.88 inches (632 mm)  
Depth = 25.25 inches (641 mm)  
Weight = 410 lbs (186 kgs)  
(without batteries)

NEBS Zone 4 6-Tier Racks	
System Part Number	Description
110-7052-01	(+) 24VDC Top Common Bus
110-7052-05	(-) 48VDC Top Common Bus

Note: Please contact C&D for additional rack options.



1400 Union Meeting Road  
P.O. Box 3053 • Blue Bell, PA19422-0858  
(215) 619-2700 • Fax (215) 619-7899 • (800) 543-8630  
customersvc@cdtechno.com  
www.cdtechno.com

Any data, descriptions or specifications presented herein are subject to revision by C&D Technologies, Inc. without notice. While such information is believed to be accurate as indicated herein, C&D Technologies, Inc. makes no warranty and hereby disclaims all warranties, express or implied, with regard to the accuracy or completeness of such information. Further, because the product(s) featured herein may be used under conditions beyond its control, C&D Technologies, Inc. hereby disclaims all warranties, either express or implied, concerning the fitness or suitability of such product(s) for any particular use or in any specific application or arising from any course of dealing or usage of trade. The user is solely responsible for determining the suitability of the product(s) featured herein for user's intended purpose and in user's specific application.